

Deflector Post



Sometimes the best defense is rolling with it.

Distributing impact energy with rock and spin capabilities, the Deflector Post protects against glancing blows—perfect for high-traffic corners. Engineered to install fast and require no maintenance, it keeps your business rolling right along.

Rotating HDPE Shell Exclusive design rocks, rolls and lifts when hit

Flexible Core Absorbs direct impacts, preventing damage to your facility

Zero Maintenance Install it once, get peace of mind for years

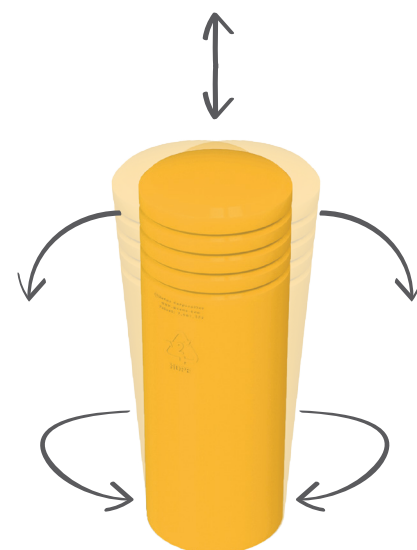

Deflector Post

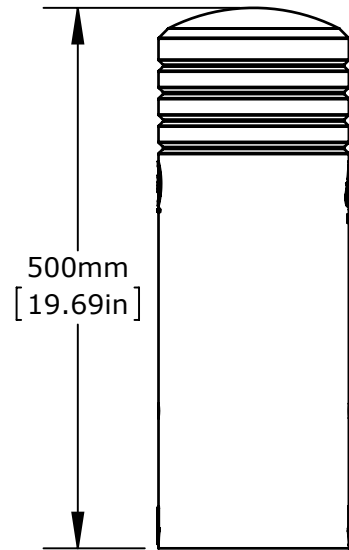
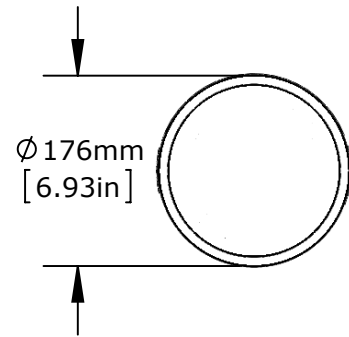
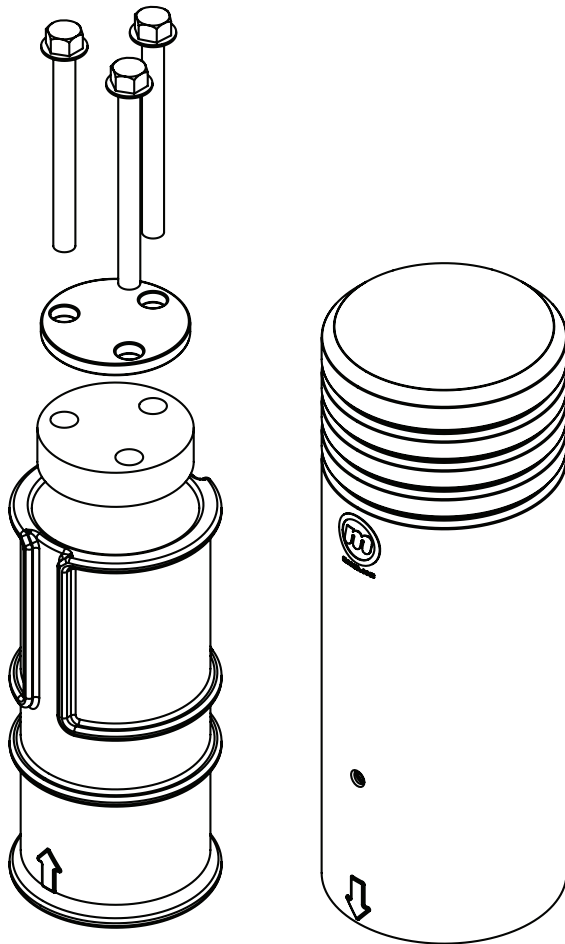

Deflector Post

17AJ601-307

Materials: HDPE shell, iron core,
rubber damper, anchor kit



**Guides your equipment around high
traffic corners to avoid damage.**